

# Capacity Subscription

Gerard Doorman  
SINTEF Energy Research

# Capacity Subscription

- Before actual consumption, consumers pay for a fuse that limits demand to fuse size in kW
- Fuses are centrally controlled and become **Load Limiting Devices**
- LLDs are activated only when there is a capacity shortage

# Characteristics

- Every consumer must have a Load Limiting Device
- Consumers must assess
  - Own demand for capacity during system-peak
  - Own preference for unlimited supply
- Consumers purchase capacity based on
  - market price for capacity
  - own preferences
- Normally, the fuse is inactive
- Under capacity shortage conditions, the LLDs are activated by the System Operator, and demand is limited

# LLD Realisation

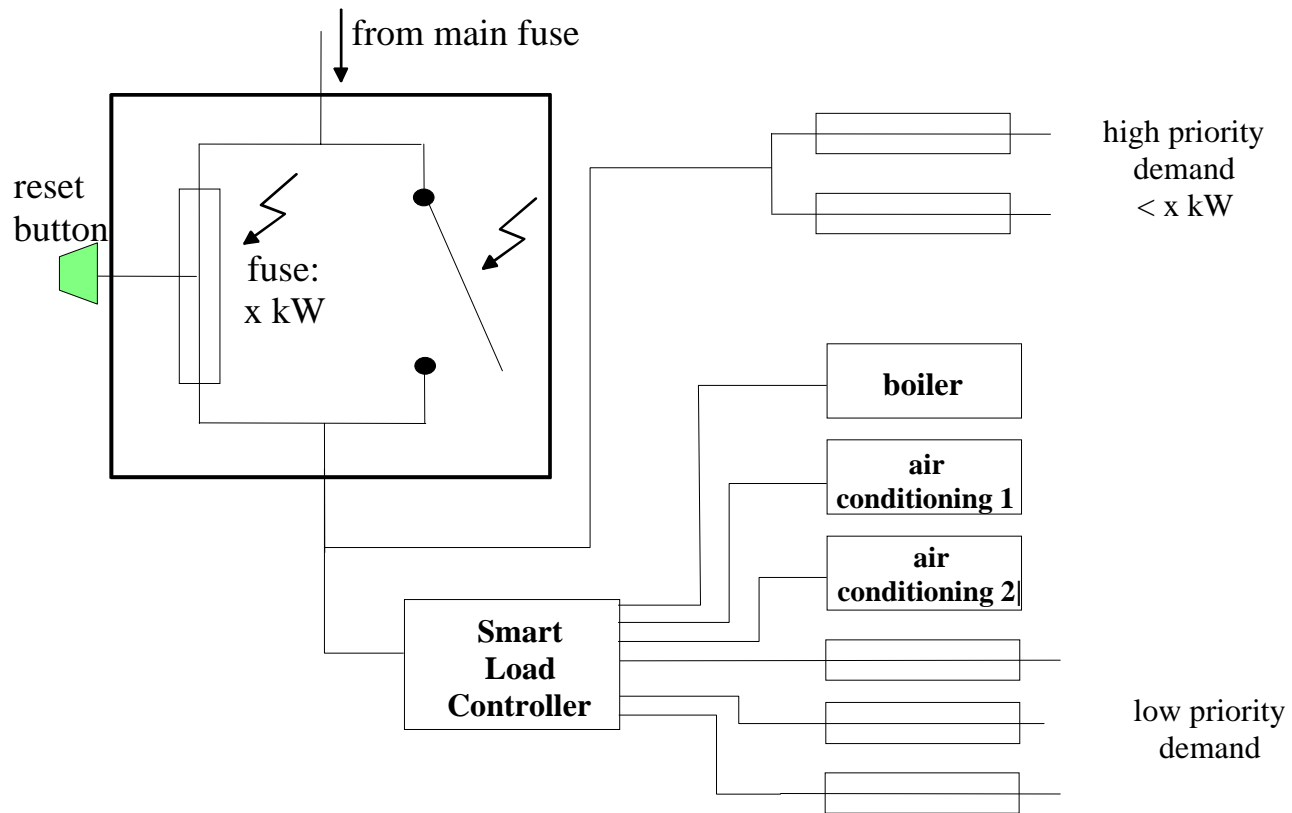

# Capacity Market

- Consumers demand capacity, based on preference for unlimited supply
- Producers can offer their expected available capacity
- Demand for and supply of capacity form the basis for the creation of a Capacity Market
- Crucial difference with existing Capacity Markets (PJM etc):

**Demand for capacity is based on consumers' preferences for unlimited supply and the price of capacity instead of experts' estimates based on the assumed need for reliability**

# Surplus situation

- Consumers subscribe to their expected maximum demand
- Fuse price is zero or very low
- Fuses never activated
- Market not affected
- No investment in peaking capacity

# Deficit situation

- If consumers prefer the present (high) level of security, the capacity price will increase
- This leads to investment in new capacity
- If consumers accept to occasionally limit demand, prices will remain low ...
- ... but there is a legitimate and acceptable way to limit demand to available supply

# Market Structure

- Capacity Subscription can in principle be implemented in various market structures
- The Capacity Market can have annual, monthly and maybe continuous auctions
- System Operator must know the sum of the fuse sizes
- System Operator keeps track of demand and decides upon fuse activation
  - before clearing of the 24-hour ahead market
    - market participants will then know this when bidding
  - or in real time
    - e.g. in the case of unexpected events
- Real time metering not necessary!

Stage/cycle	System operator	Market operator	Producer	Retailer and Trader	Customer	
Yearly	Calculation of tariffs					
Monthly/ weekly	ROM-options		ROM bids		ROM bids	
	Load forecast	Capacity contracts	Price forecast	Price forecast		
			Operating strategy	Operating strategy		
			Selling capacity	Trading capacity	Buying capacity	
Price area definition			Selling energy	Buying energy		
Daily	Load forecast LLD activation warning	Option contract	Risk analysis	Risk analysis		
		Future and forward contracts	Risk management	Risk management	Risk management	
			Preliminary schedules			
	Spot stage	CfD			Demand forecast	
		Spot market price calculation		Elspot bids	Elspot bids	Elspot bids
		Elbas		Elbas bids	Elbas bids	Elbas bids
Pre-operational stage	BM, merit order price list		Balancing bids		Balancing bids	
	Overview on schedules and reserves		Final schedules			
Operational stage	Deviation from plan	Clearing				
	BM activation					
	LLD activation					
Post operational stage	Accounting Invoicing	Invoicing	Invoicing and paying	Invoicing and paying	Paying	

Capacity Market

Activation Evaluation

LLD Activation

Settlement

# Challenges

- Complexity / customer accept
  - but: in Norway a two-price capacity tariff was dominating until the mid-eighties
  - Education
- How to estimate one's need for capacity
  - Internet-based demand calculator
- What happens when subscribed limit is exceeded during fuse activation
  - manual reduction – doubtful
  - advanced electronic load control
  - alternative: two-price system with very high violation penalty (1-2 Euro/kWh?)
- Infrastructure cost

# Demand Calculator - Result

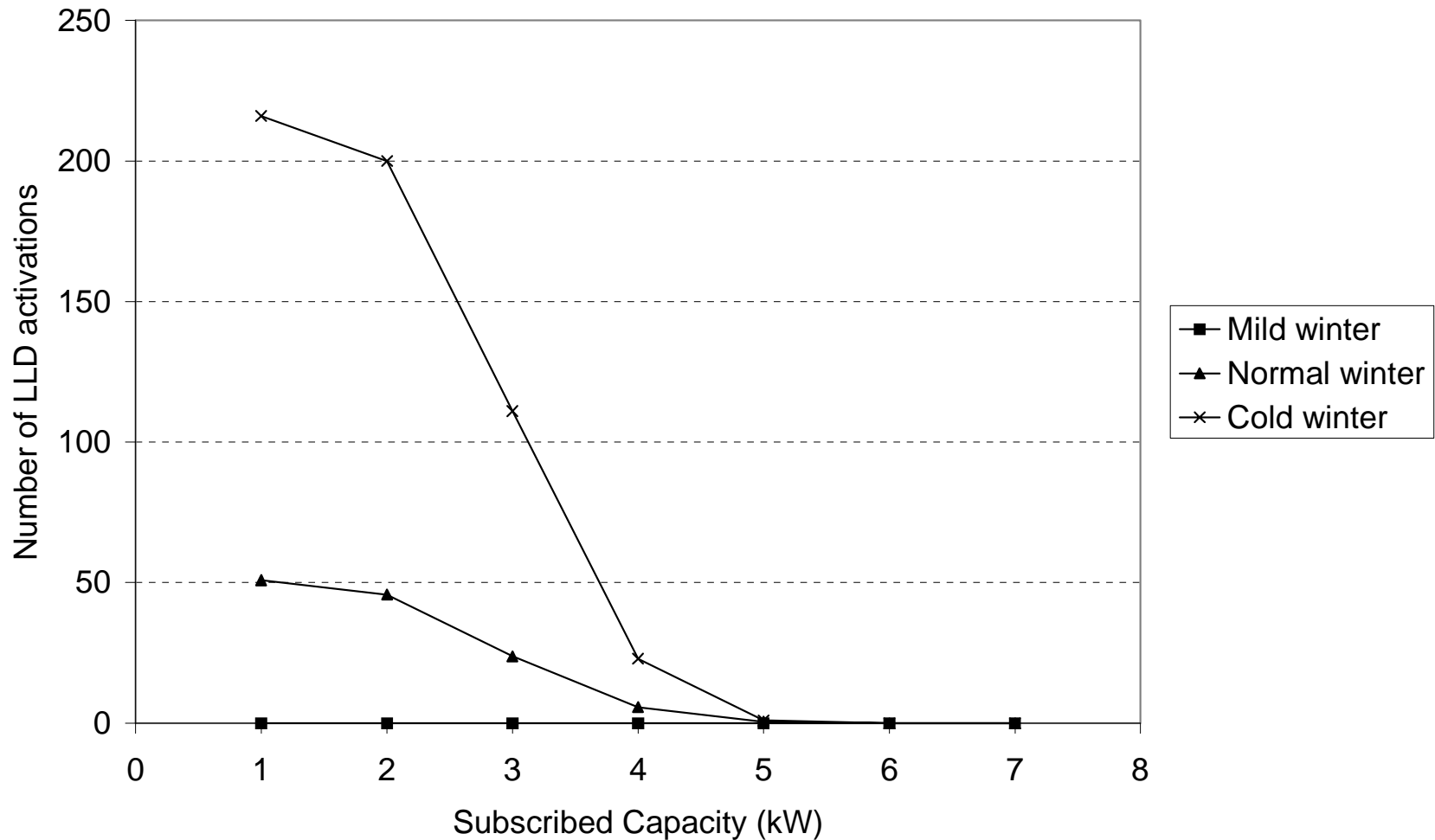

# Demand Calculator – Cost Estimate

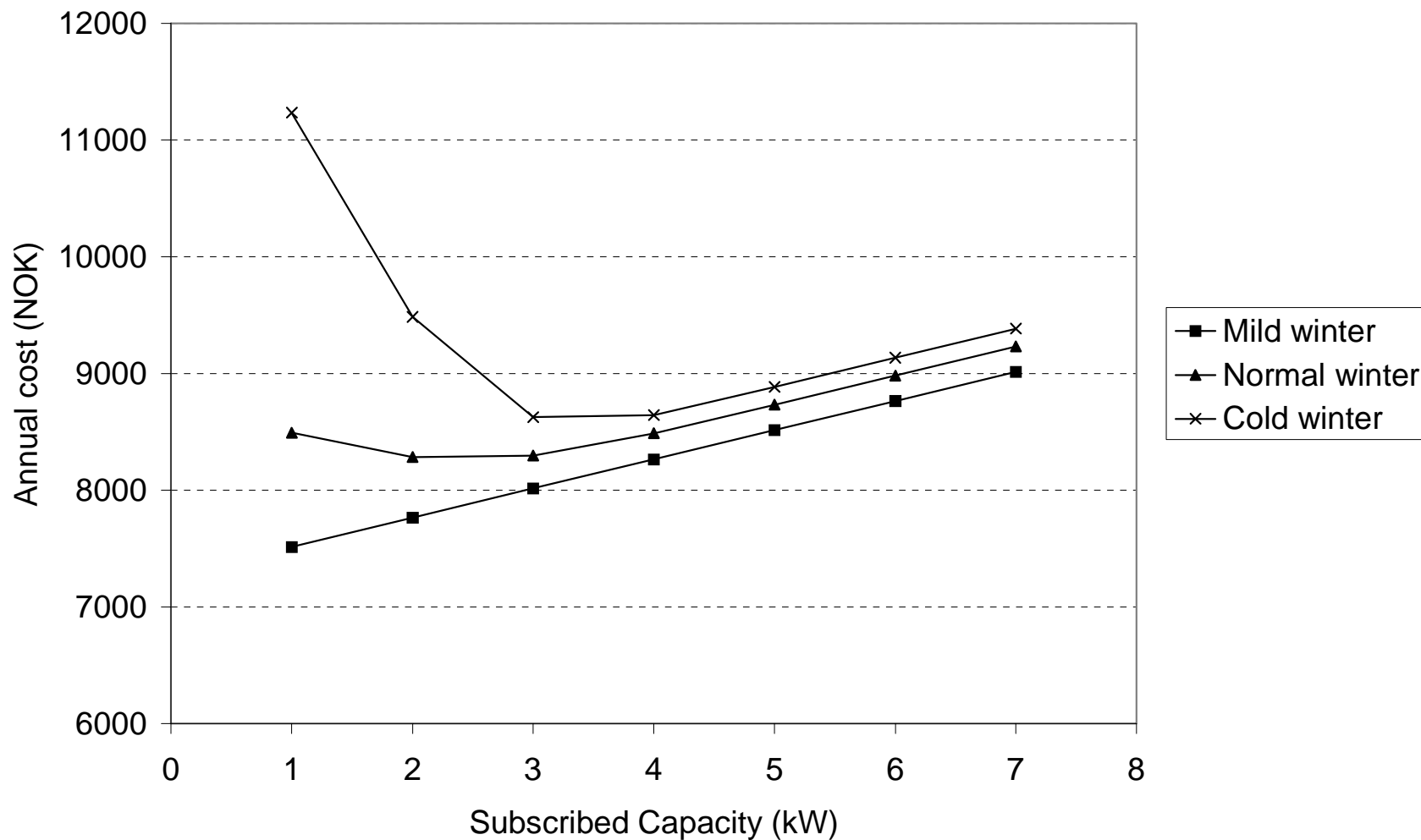

# Advantages

- Consumers choose their preferred reliability level
- System reliability ensured
- Reliability (adequacy) becomes private (as opposed to public) good
- Enables creation of capacity market
- Motivates technological change (dynamic efficiency)
  - Smart demand-side solutions vs generation capacity
- Hourly metering not necessary

# Disadvantages

- Initially complicated for consumers
  - → "default" solution?
- Most customers must be willing to limit demand occasionally
  - If no customers at all are willing ever to have demand limited, the total need for capacity is the sum of their individual maximum demand
- Requires new infrastructure
  - Communication
  - Control
- Considerable initial investment

# Further research

- Comparison with other "dynamic" solutions, e.g.
  - Spot pricing
  - Reliability contracts
  - PJM, new version (flexible demand for capacity)
- Try-outs
  - Technology
  - Consumer communication and acceptance
- Market simulation

# Conclusions

- Capacity Subscription basis for two-sided Capacity Market
- Investment in supply based on capacity prices
- Generation capacity will be based on real consumer preferences instead of hypothetical questions
- (A part of) security of supply becomes a private instead of a public good
- Motivates technological innovation (dynamic efficiency)
- Initially complicated and expensive
- May be a realistic alternative to full spot pricing